

Section insulator ZT1

V 2025/01

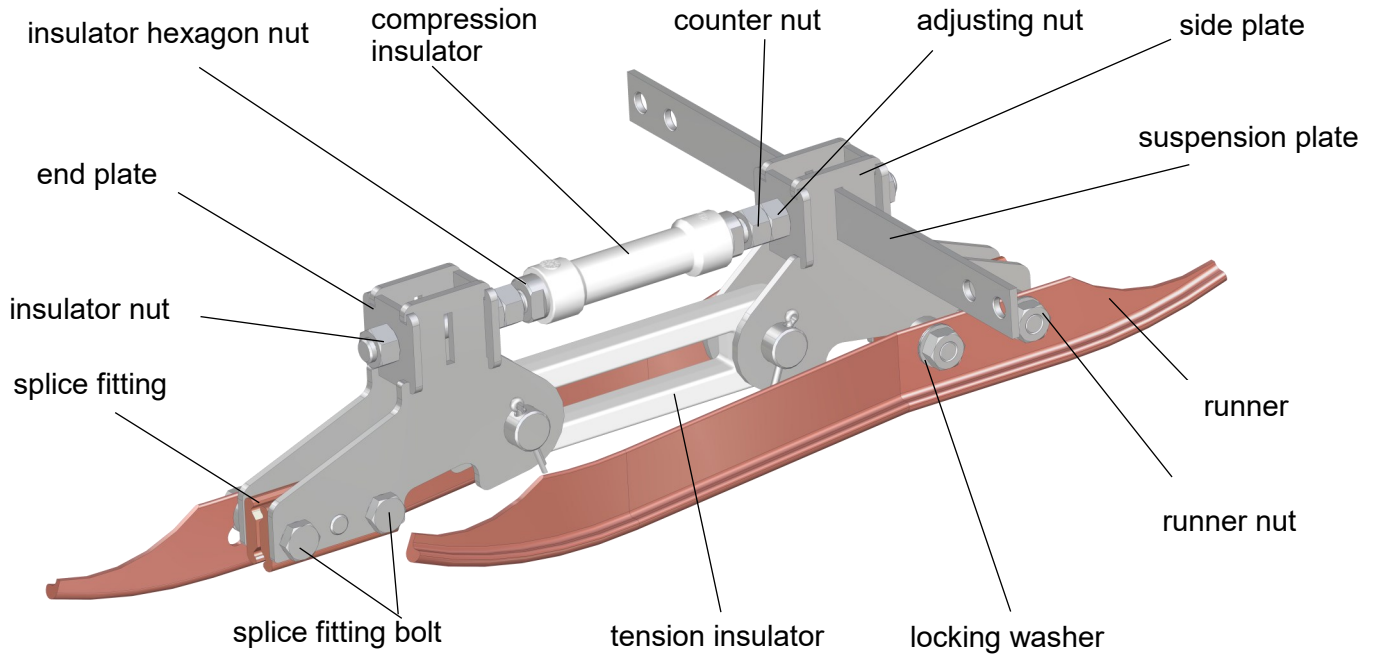

Optional supplies:

Turnbuckle:

art. no. 690.038.000

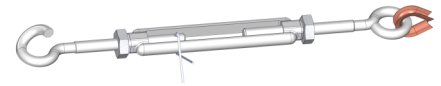

Recommended tools:

Installation JIG

art. no. 655.455.201

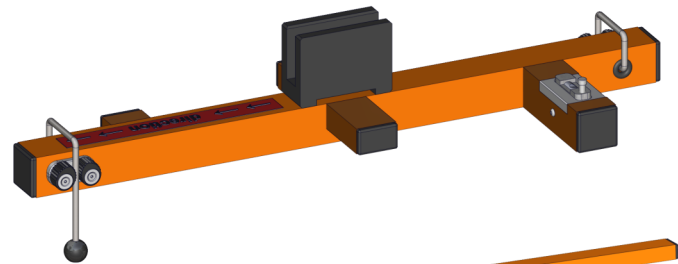

Alignment bar

art. no. 696.016.010



Index

A. Tools.....	2
B. Preparation.....	2
C. Installation.....	4
D. Installation without suspension.....	9
E. Maintenance.....	9
F. Legal information.....	10



RISK OF DEATH

Before working on the overhead line: Ensure that the overhead line is de-energized and properly grounded according to the regulations.

A) Tools

- 1 Ring open wrench 17 mm art. no. 656.000.001
- 1 Ring open wrench 19 mm
- 1 torque wrench 17 mm (50 Nm)..... art. no. 655.114.000
- 1 adjustable spirit level..... art. no. 655.141.000
- 1 bolt cutter or metal saw art. no. 656.000.002
- 1 copper hammer..... art. no. 656.000.009
- 1 straightening wood..... art. no. 656.000.005
- 1 file
- 1 measuring tape art. no. 656.000.006
- 1 pulley block (when a section insulator is replaced)

B) Preparation

1. Preparation of contact and messenger wire

Straighten the contact wire at the installation location and make sure it is not twisted.

Each section insulator should be well centred and aligned parallel to the track. The carbon strip of the pantograph must run centred over the section insulator.

Align the contact wire and the messenger wire in the middle of the track (+/- 50 mm).

The contact wire and messenger wire must be positioned vertically within 50 mm above each other.

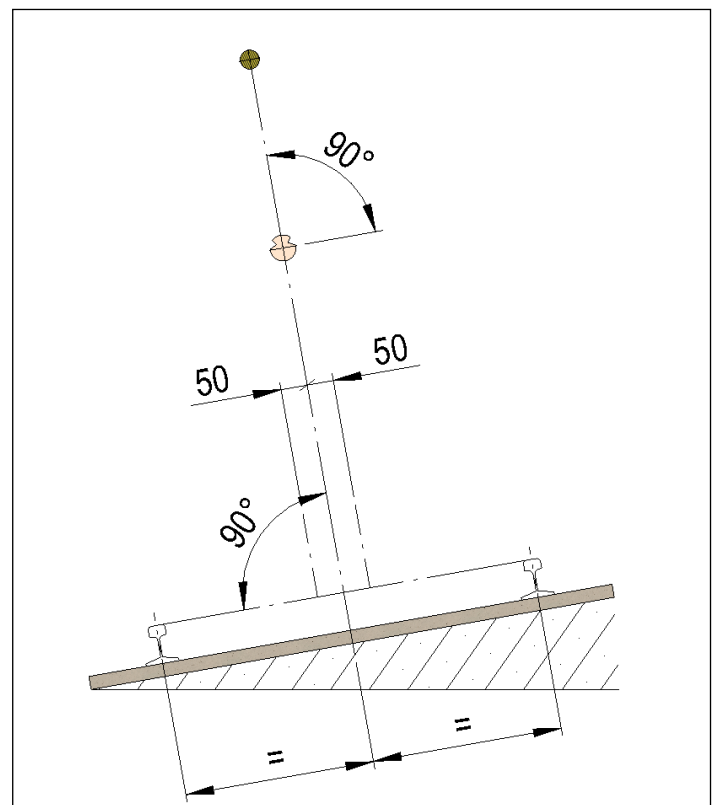

2. Installation location

If the installation is done with Delta Wire, the section insulator **must** be installed with the suspension.

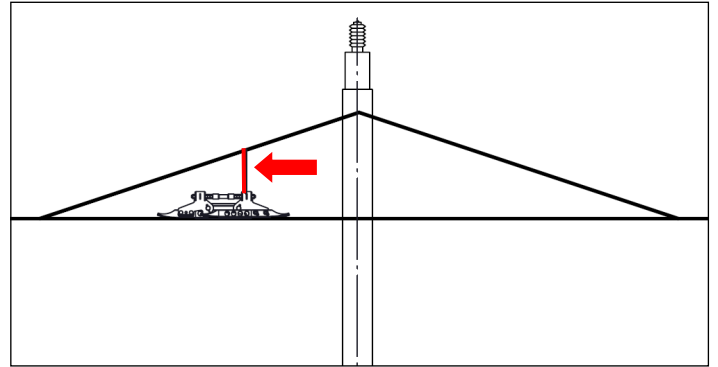

If the installation is done with messenger wire, the section insulator should be installed with a suspension and at least **2 m** away from the guide arm.

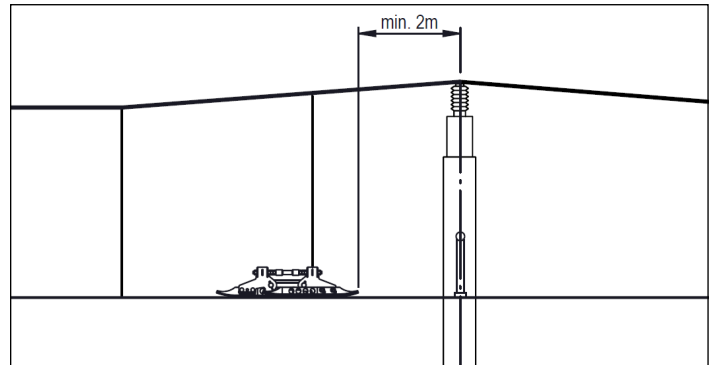

The sloping angle of the messenger wire should not exceed 5° if saddle clamps are able to glide.

If the installation is carried out without a messenger wire, the section insulator must be installed max. **1 m** away from the guide arm.

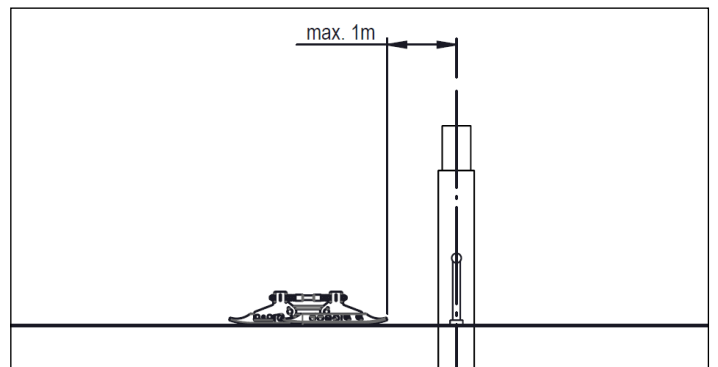

3. Measure the cant of the track

Measure the cant of the track without installation JIG

Place the adjustable spirit level on the alignment bar at the installation site as shown and adjust the spirit level.

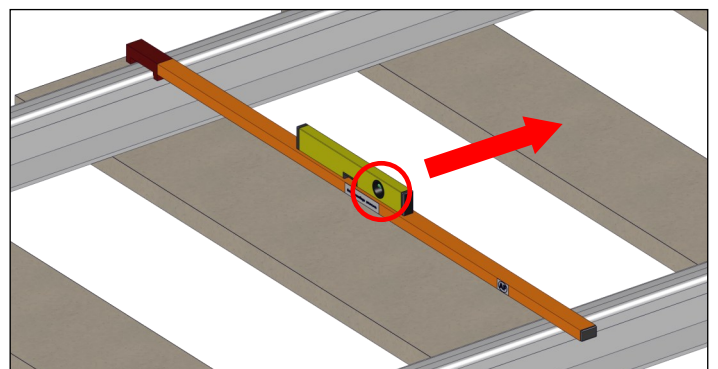

Measure the cant of the track with installation JIG

Place the installation JIG on the alignment bar and adjust the integrated spirit level.

The orientation of the JIG can be chosen freely but must be maintained during the installation.

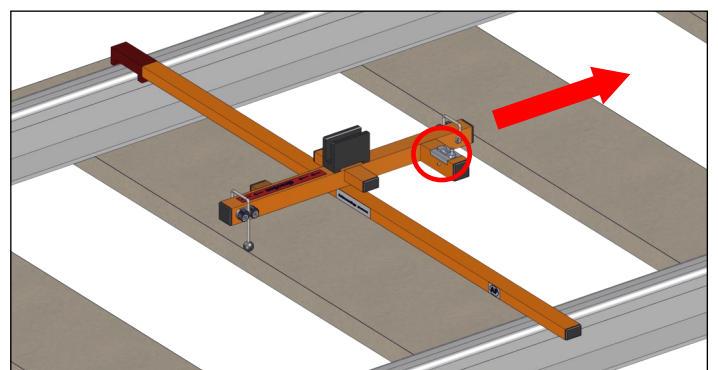

4. Determine the hogging

Final height of the section insulator =
Standard height of contact wire + hogging of
at least 30 mm.

The standard height of the contact wire is the original contact wire height without the weight of the section insulator.

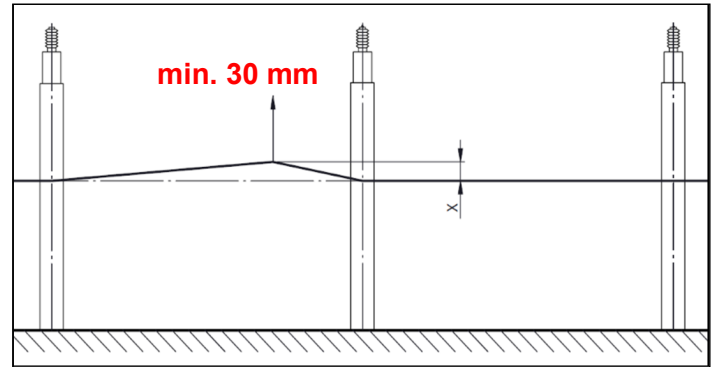

C) Installation

5. Preparation of the splice fittings

Slightly loosen the two insulator nuts.
Loosen the six splice fitting bolts.
Spread the two splice fittings.

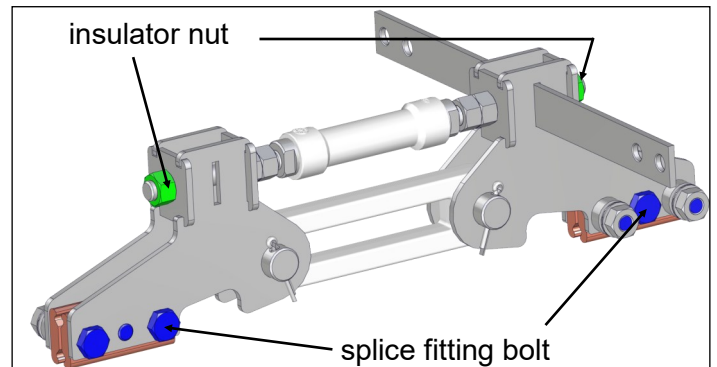

Insert a piece of contact wire in the upper part of each splice fitting.

The inserted contact wire pieces must have the same groove size as the contact wire at the installation site.

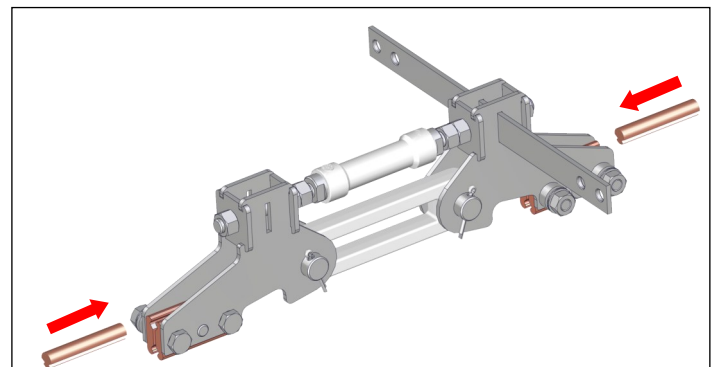

6. Installation of the section insulator body on the contact wire

Place the section insulator on the contact wire with slightly spreaded splice fittings and check that the splice fittings are correctly placed into the contact wire groove.



Warning: The teeth of the splice fittings must grip in the contact wire groove over the full length of the splice fittings.

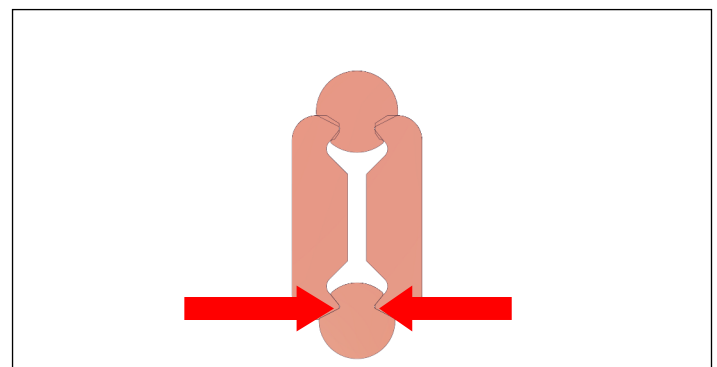

Tighten all bolts of the splice fittings one after the other with a torque wrench to **50 Nm**. Repeat this process twice until each bolt has been tightened a total of three times.

Start with the bolt 1 on the inner side of the splice fittings, then tighten the bolts 2 + 3.

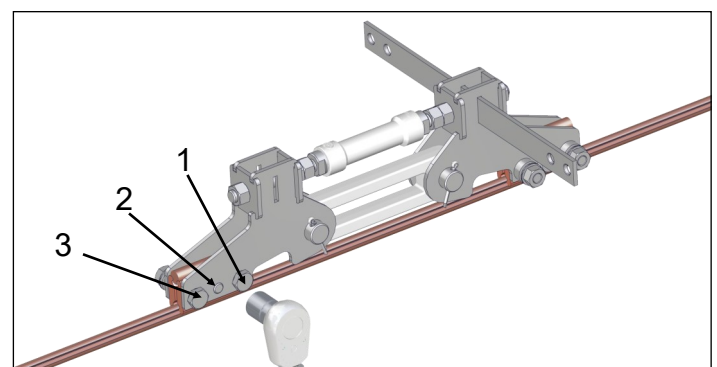

7. Cut the contact wire

Cut the contact wire below the intended notch in the side plate on both sides of the insulator body using a bolt cutter or a metal saw.

Deburr the cutting surface with a file.

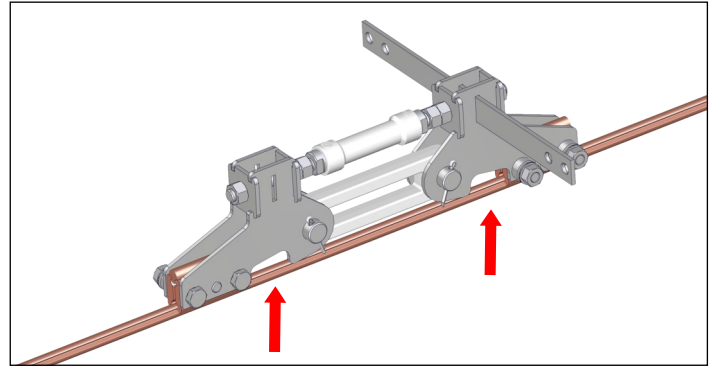

Bend up the contact wire ends by hitting them with a hammer.

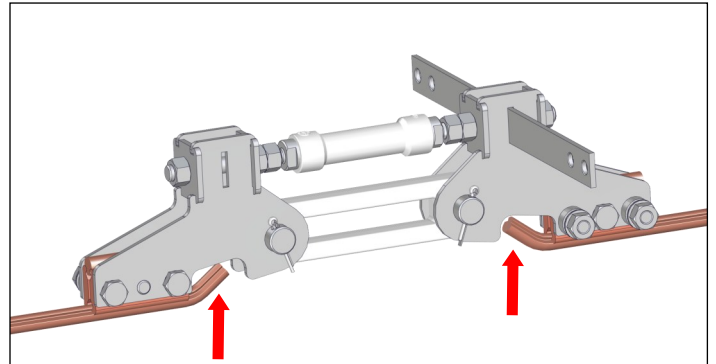

8. Hogging of the section insulator

Mount the turnbuckles and the suspension.

Adjust the hogging according to the hogging instructions in point 4.

Tension the suspension until the tension is taken over by the cable droppers.

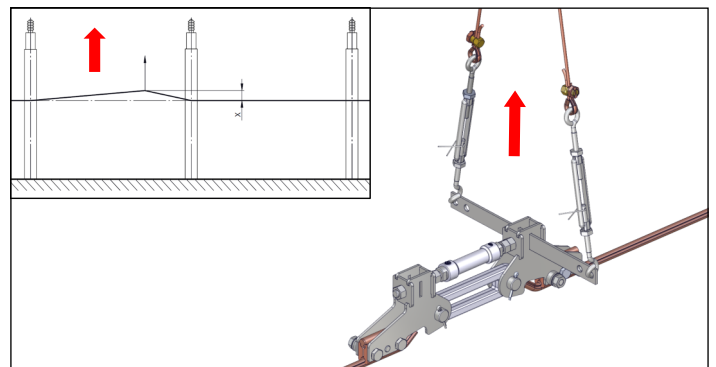

Tighten all locking bolts and lock the turnbuckles with a safety wire.

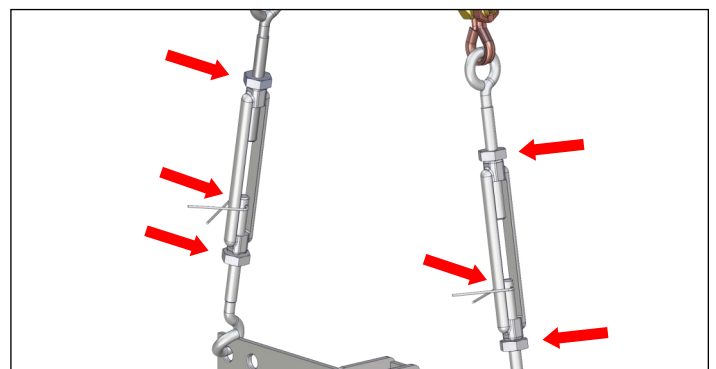

Tighten both cable dropper clamps to **25 Nm**.

The tension in the two cable droppers must be the same.

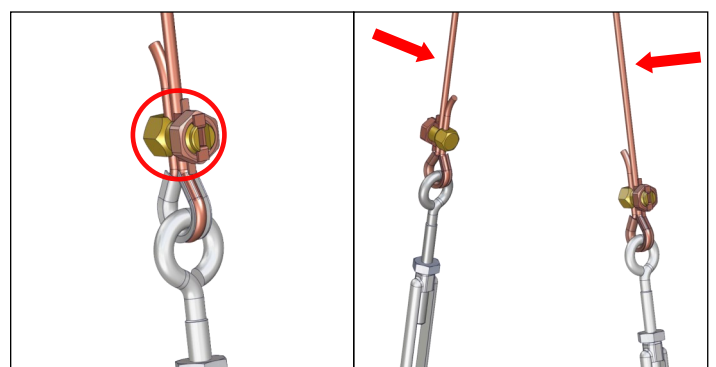

9. Aligning the section insulator body

Adjust the pretension (horizontal position) with the adjusting nuts. Hold the insulator hexagon nut with a open-end wrench.

Check the alignment with a spirit level.

Adjust the compression insulator so that both splice fittings rest straight and hold the contact wire without deflection.

The contact wire must not have any deflection.

Lock the adjusting nuts with the counter nuts. Hold the insulator hexagon nut with an open-end wrench.

After aligning the isolator body, tighten both insulator nuts to **25 Nm**. Hold the insulator hexagon nut with an open-end wrench.

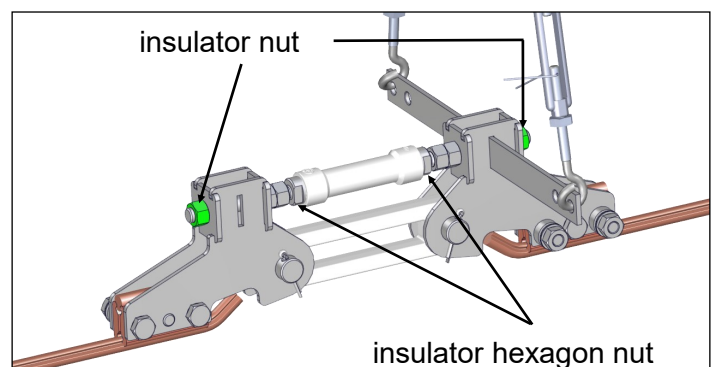
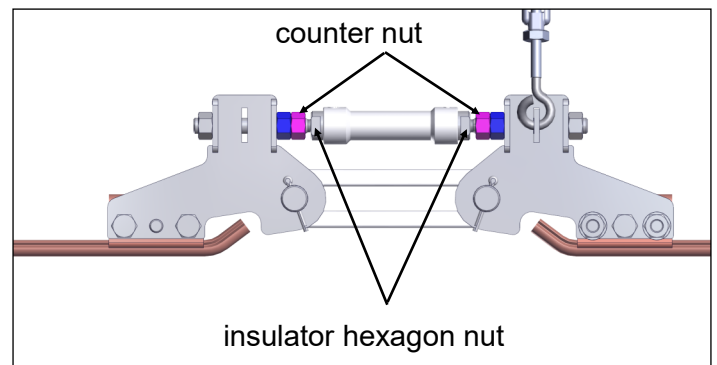
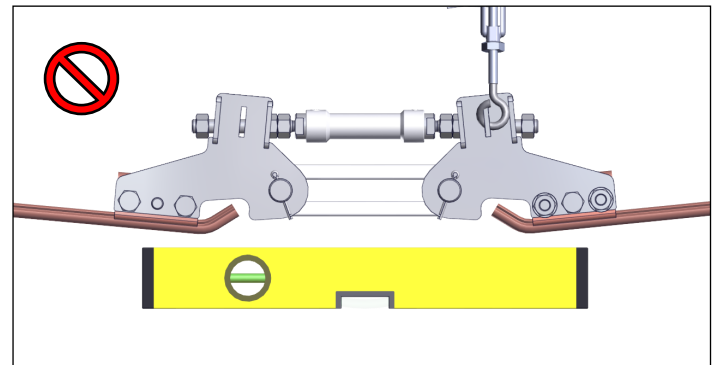
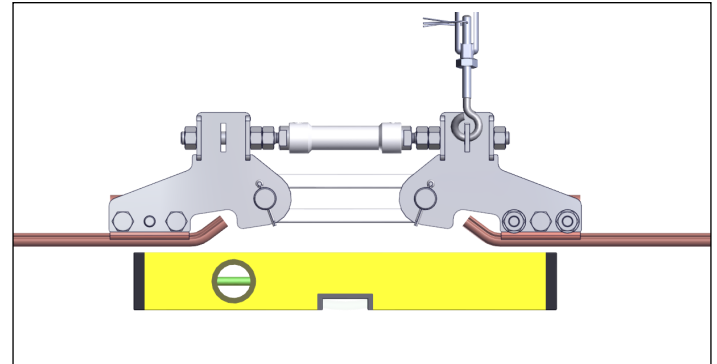
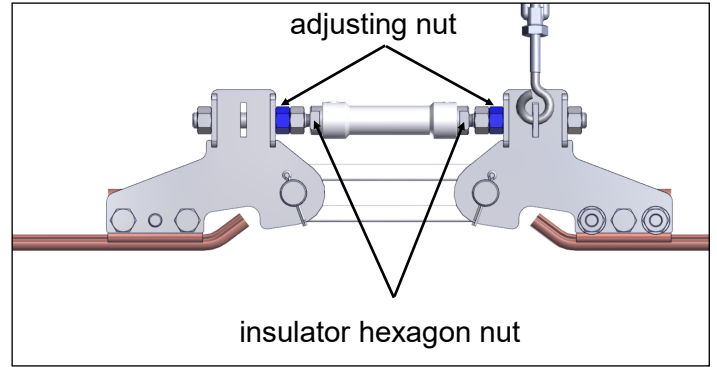

10. Adjust the cant

Adjust the cant of the section insulator on both sides using the turnbuckles and check it with the spirit level according to point 3.

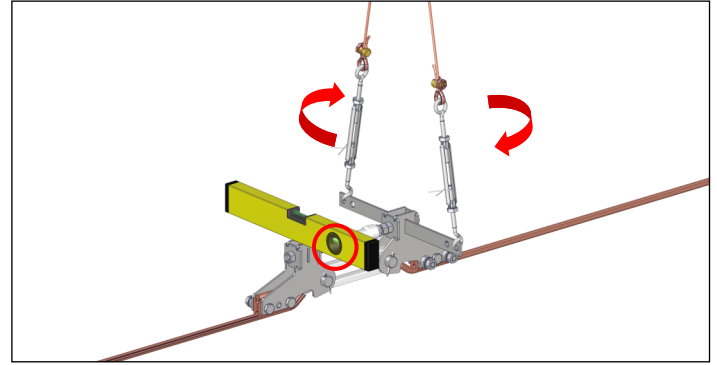

11. Attachment of the runners

Unscrew the nuts and locking washers.

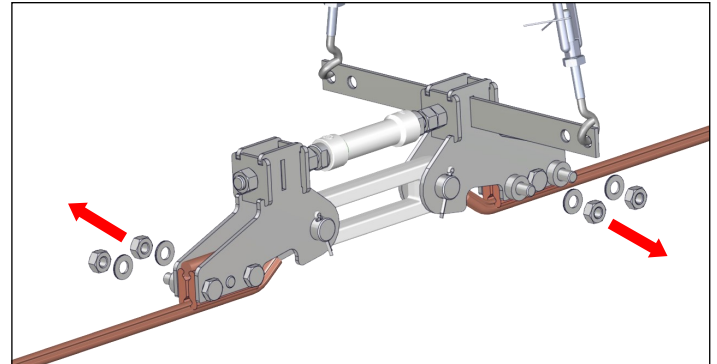

Install the runners to the insulator body using the locking washers and nuts.

Lightly tighten the nuts.

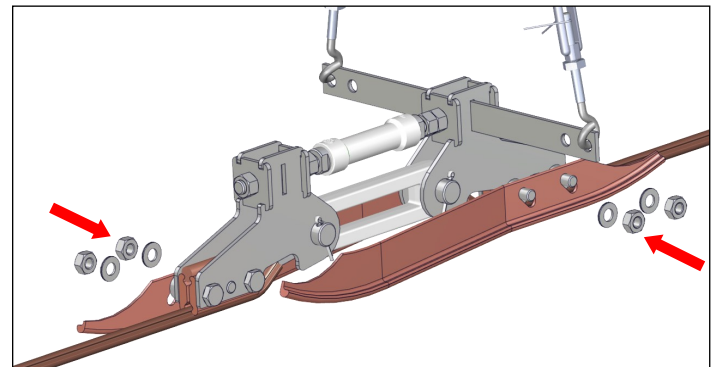

12. Check the running properties

Check the running properties and cant of the track according to point 3 with a spirit level. The runners must be aligned parallel to the track.

1. The transition from the contact wire to the runners must be smooth.
2. The runners must be installed parallel to the track and at contact wire height.
3. The transition from the runners to the contact wire must be smooth.

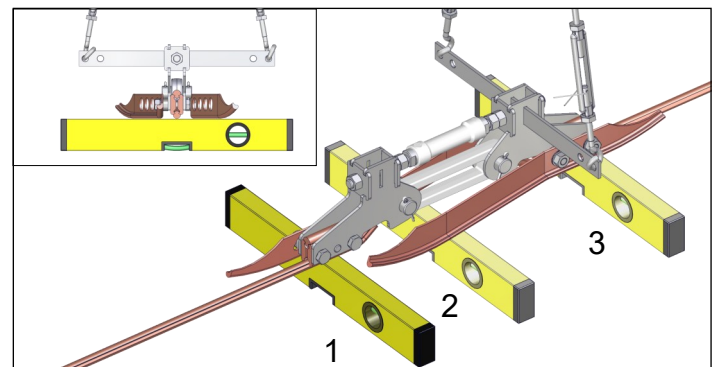

Tighten the nuts of the runners to **50 Nm** on both sides.

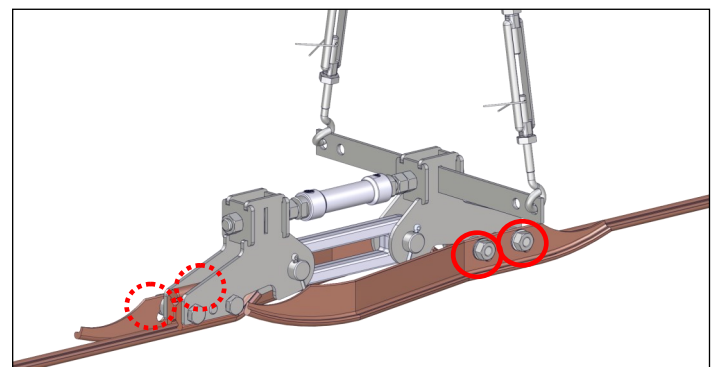

13. Attachment of the runners with installation JIG

Attach the installation JIG in the direction chosen in point 3 below the section insulator.

Attach the installation JIG to the contact wire using the ropes.

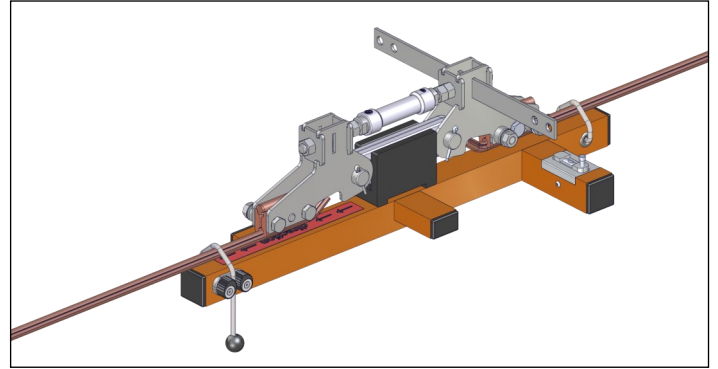

14. Adjust the cant

Adjust the cant of the section insulator on both sides using the turnbuckles and check it with the integrated spirit level according to point 3.

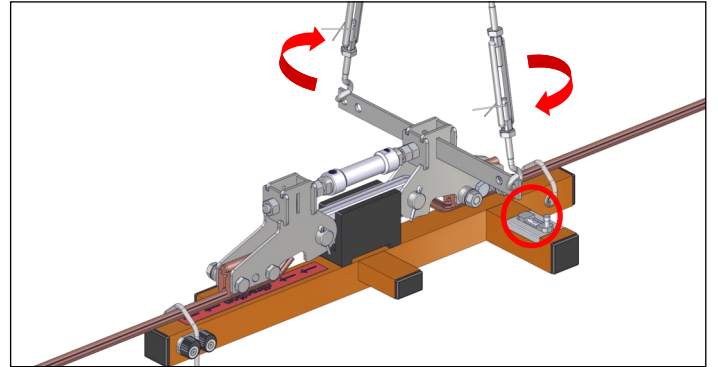

15. Attach the runners

Unscrew the nuts and locking washers.

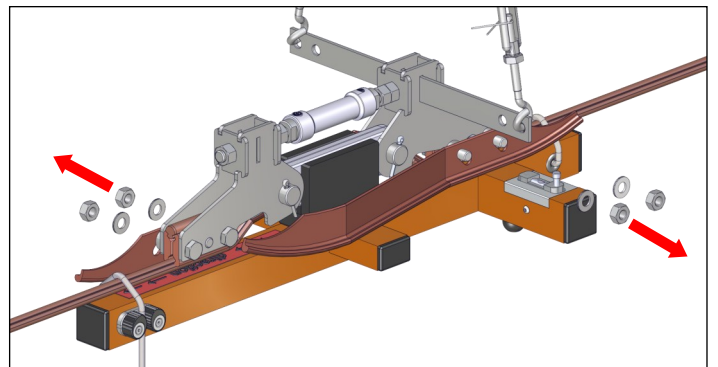

Install the runners to the insulator body using the locking washers and nuts.

The runners must rest on the cross struts of the installation JIG on both sides.

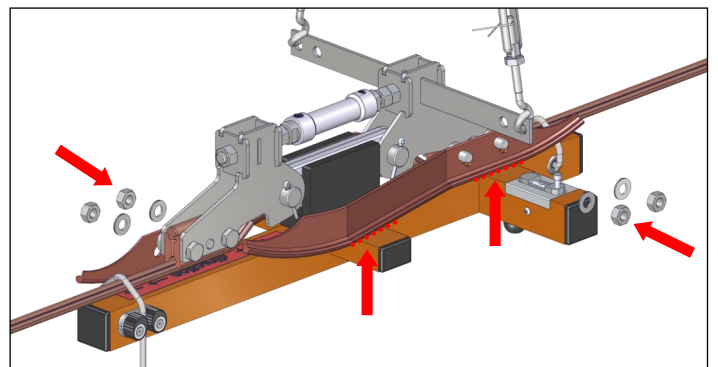

Tighten the nuts of the runners to **50 Nm** on both sides.

Remove the installation JIG from the insulator body.

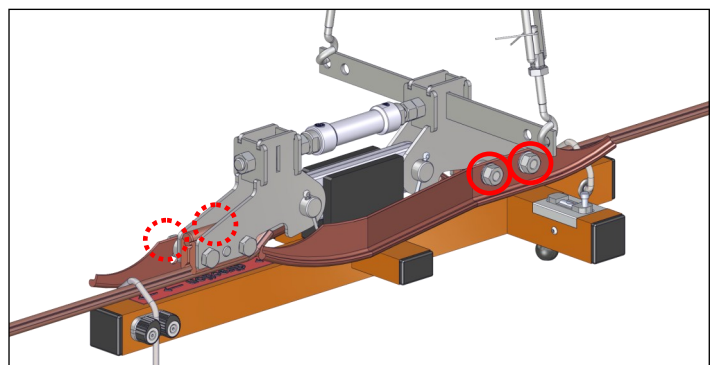

16. Check the running properties

Check the running properties and cant of the track according to point 3 with a spirit level. The runners must be aligned parallel to the track.

1. The transition from the contact wire to the runners must be smooth.
2. The runners must be installed parallel to the track and at contact wire height.
3. The transition from the runners to the contact wire must be smooth.

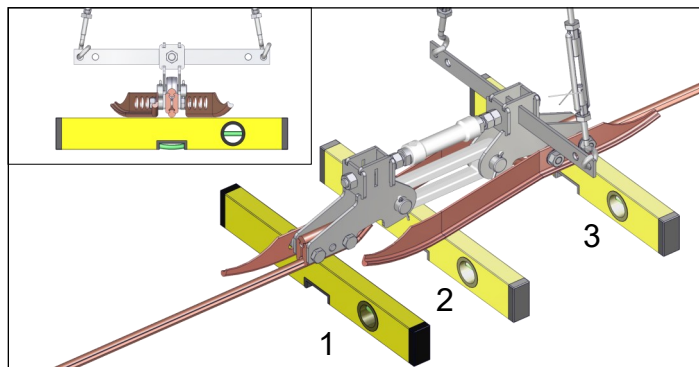

D) Installation without suspension

Install the section insulator according to points 1 to 12 without hogging (point 8) and adjusting the cant (point 10).

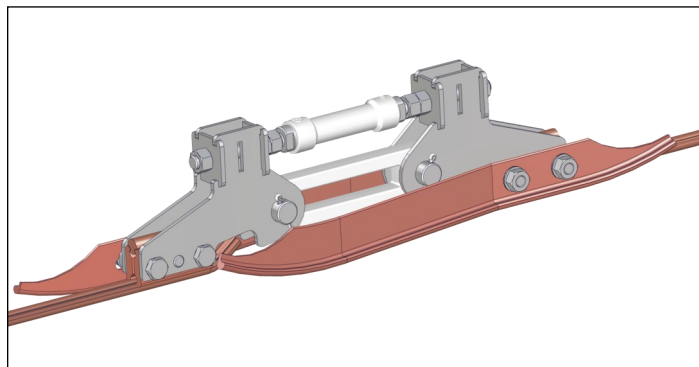

E) Maintenance

A correctly adjusted Arthur Flury AG section insulator requires no maintenance over a long period of time.

Insulator

The insulators are usually sufficiently cleaned by rain. In the case of extreme soiling (e.g. due to regular use of diesel engines or when installed in a tunnel, etc.), we recommend cleaning the section insulator with water and commercially available soap.

If there is visible damage to the insulator cover, the insulator must be replaced immediately.

Runners

If the runners show increased wear at the entry, it indicates that they have not been adjusted accurately enough. The runners must be readjusted according to the installation instruction. Well adjusted runners show even wear over the entire length.

Should the wear have reached the maximum value (bulb only 2 mm) the runners must be replaced.

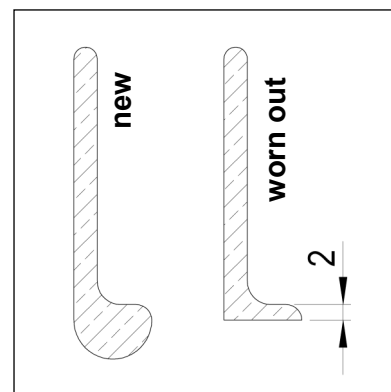

Running properties

The section insulator must remain stable during the passage. If the installation vibrates strongly or even becomes loose, this is a sign that the pantograph is creating too much pressure on the section insulator. In this case the section insulator must be positioned higher (increase hogging).

F) Legal information

The product must only be operated by trained specialists.

The product can be permanently damaged by loads that exceed the maximum values. If the product is exposed to absolute maximum loading for an extended period, it may impair the product's reliability and life. Arthur Flury AG will not accept any liability in this case.

Arthur Flury AG will not accept any liability for incorrect use and use for applications other than those specified in these instructions.

If damage to the product is suspected, any use or operation must be stopped immediately. Arthur Flury AG will not accept any liability in the event of continued use despite suspected damage.

Due to the diverse ways in which this product can be used, the instructions for use represent a general guide only and do not constitute a guarantee of the product's suitability for use in a specific application. The user is responsible for checking the full product data and clarifying the product's suitability for the intended use. The user is responsible for the choice of product and compliance with all the safety regulations and warnings. Please contact Arthur Flury AG if you require additional product information.

Our products comply with the current legal requirements and regulations (including RoHS, REACH, WEEE) in the markets where we operate. Please refer to Arthur Flury AG's Code of Conduct, available on our website, for further information.

These instructions are intended to provide the customer with information and should not be supplied unless accompanied by the product. The products and information in this publication require appropriately trained specialist personnel. Despite the greatest care being taken, the instructions may contain inaccuracies or typographical errors for Arthur Flury AG will not accept any liability. Arthur Flury AG may amend the instructions at any time, without notice, in the interests of technical progress. The customer is responsible for downloading an up-to-date version of the instructions from Arthur Flury AG's website before using the product.

Any brand and product names used in these instructions are registered marks ® or trademarks™ of their respective owners.

Arthur Flury AG will not accept any liability for damage incurred as a result of failure to comply with these instructions.



Arthur Flury AG